

# FLOOR PLANS

±4,809 SQ FT

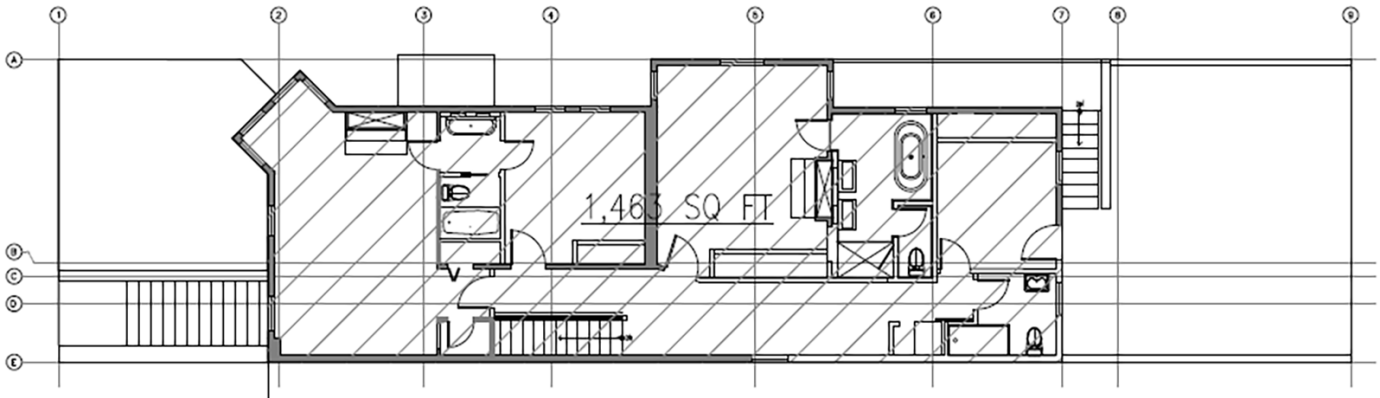

3rd Floor | ±1,463 SQ FT

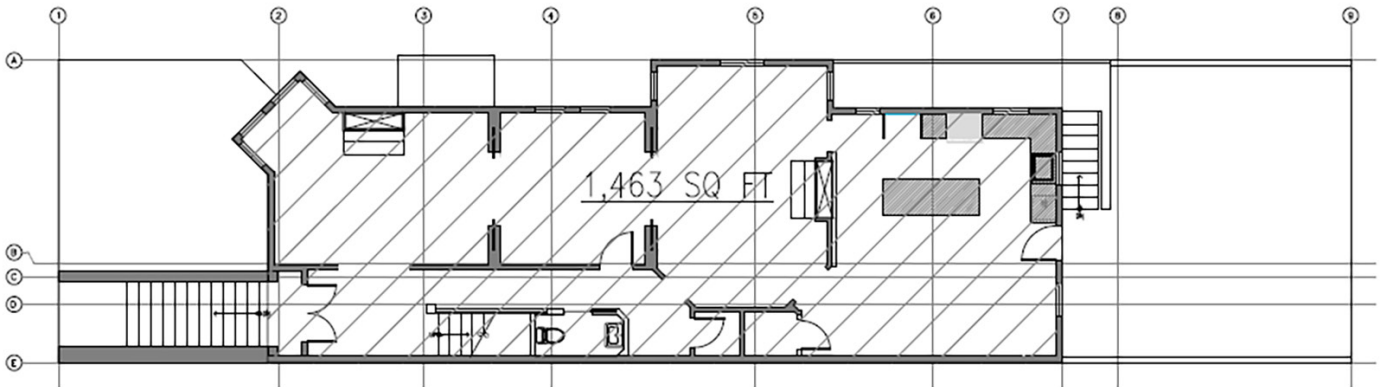

2nd Floor | ±1,463 SQ FT

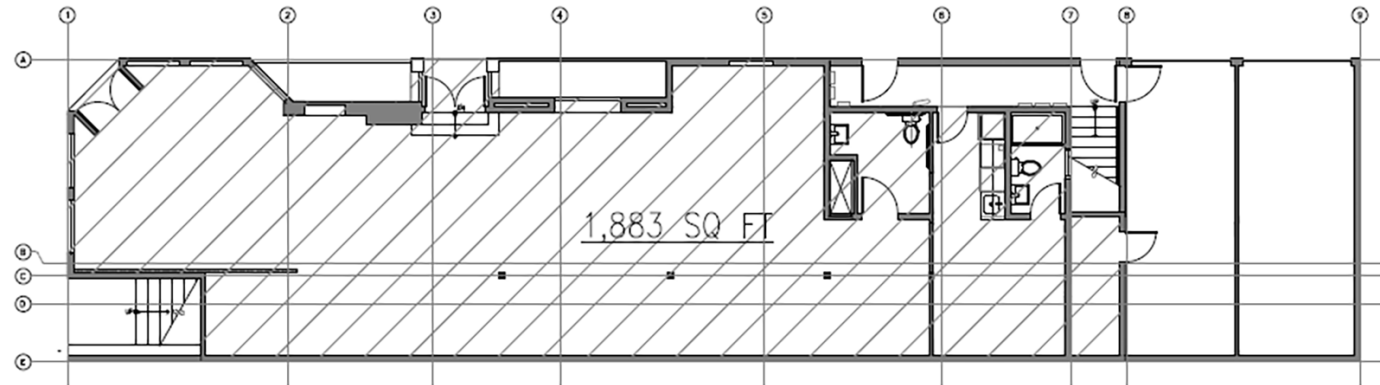

1st Floor | ±1,883 SQ FT



INCORPORATED | EST. 1922

This Statement with the information it contains is given with the understanding that all negotiations relating to the purchase, renting or leasing of the property described above shall be conducted through Blatteis Realty Company. The above information, while not guaranteed, has been secured from sources believed to be reliable. Blatteis Realty has not verified its accuracy and make no guarantees, warranty or representation regarding this information and it is published subject to the possibility of errors, omissions, changes of listing information including price, term, financing, or withdrawal without notice. We include projections, estimates, opinions and/or assumptions, for example only, and they may not represent current or future performance of the property. You should consult your tax and legal advisors before to verify the validity of estimates.

**JEREMY BLATTEIS**

415.321.7493 | [jfb@brsf.co](mailto:jfb@brsf.co) | DRE #01460566

[sfretail.net](http://sfretail.net)